

KWIK-WAY®

Frustrating the Competition for 85 Years



**Many have tried, some have come close
But None have duplicated the Accuracy of the
*Kwik-Way Six-Ball Centerlining Chuck***

**Based on fundamental design principles
that existed in 1920 and still exist today,**

***Kwik-Way Remains The Most Accurate
Valve Grinding System Ever Conceived:***

.0002 or less*



SSV II Deluxe Valve Refacer

* with High Performance Chuck

www.kwik-way.com

800-553-5953

SVS II Deluxe Valve Refacer

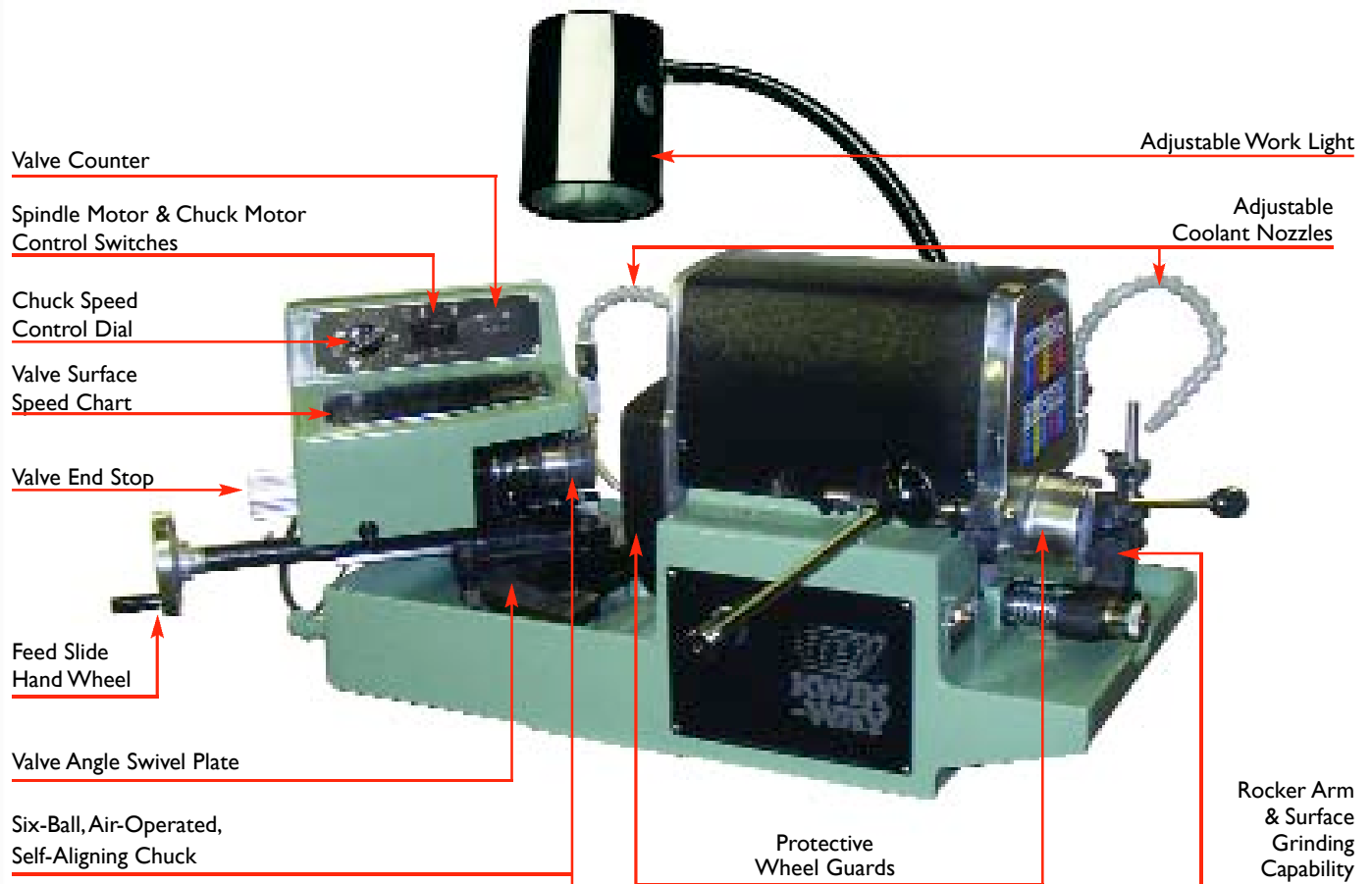

EXCLUSIVE SIX-BALL CHUCK DESIGN

Every Kwik-Way SVS II is equipped with this air-activated, self-aligning six-ball chuck that is accurate to within .0005" (.0002: with High Performance Chuck).

Six-Ball alignment for perfect grinding

Every Kwik-Way chuck features two sets of balls - 3 to a set - which grip the valve stem on that part which travels in the valve guide.

Independent studies have concluded that the *Kwik-Way Centerline System* grinds valves with greater accuracy than other collet, conical-centering or centerless chuck design machines..

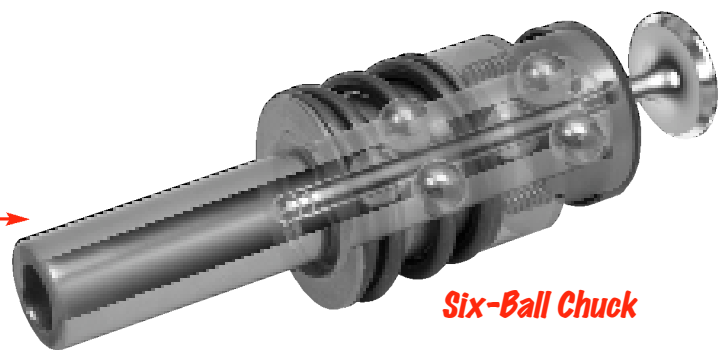

Six-Ball Chuck

The Kwik-Way Principle: CENTERLINE

The Kwik-Way "**Centerline System**" is the only way to correct and align valve faces to that portion of the valve stem operating in the guide. Unless a valve is scientifically aligned, the valve face will be ground eccentric to its true center. A new valve is true and mechanically accurate in all its proportions. The valve face and stem are concentric with the same centerline.

Warping occurs only in that part of the valve that is subject to extreme heat - the portion above the guide and in the valve head. To correct a warped valve so it will function properly when replaced in the engine, the valve face must be restored to concentricity with the portion of the stem that operates in the guide. The "**Centerline System**" assures this alignment and accuracy.



Air-Activated • Self-Aligning • No other system is as accurate and precise

Designed with You in Mind

Features

Air-Operated, Six-Ball Chuck

Consistent Accuracy

Valve Stems: 4.0mm to 14.3mm
(Up to 21mm with optional chuck assy)

Variable Speed Chuck

Saves Time

Stem Grinding

Rocker Arm Grinding

Adjustable Swivel Plate

Designed for Safety

Superior Visibility

Clean Operation

Longer Wheel Life

Diamond Dressing Arm

Storage Cabinet

Benefits

Self-Aligning and accurate to within .0002" with the optional High Performance Chuck - .0005 with standard chuck.

Two sets of 3 balls automatically find the existing valve stem centerline to assure valve grinding accuracy.

Other machines can require up to 9 separate collets to achieve the same range.

Valve faces are made from different materials and also have various diameters. To provide consistent finishes, Kwik-Way's infinitely variable speed chuck allows the operator to vary the valve speed quickly and accurately to provide the optimum finish.

Air-activated chuck opens quickly to its full diameter with the touch of a button. Work through a wide range of valve sizes without stopping to change collets or make chuck adjustments.

Standard attachment for butt-end grinding and stem chamfering increases the equipment's capabilities.

The rocker arm attachment (standard on the SVS II Deluxe) allows quick refacing of most shaft-mounted rocker arms.

The valve position swivel plate adjusts in 1° increments from 13° to 62° to assure accuracy of the grinding angle.

The exposed area of the grinding wheel faces away from the operator and is shielded by the protective housing.

Operator looks directly at the valve face without leaning over the machine.

Coolant stays in the machine - doesn't spray the operator or the work area.

Kwik-Way Original Equipment Wheels, grinding oil and diamonds assure longer wheel life by requiring less frequent dressing - that means more valves serviced.

Swivels into the last position used and is locked without the need for special tools or wrenches.

Optional Heavy Duty Cabinet and floor stand provides convenient storage and conserves space.

SUPERIOR FINISH: Kwik-Way's separate, belt driven spindle isolates any motor vibration or harmonics to provide a smooth "chatter free" finish. Kwik-Way offers a wide variety of grinding wheels to fit your specific needs from general purpose to specialty applications such as titanium and hard alloy valves. The variable speed chuck and precise spindle speed meet the grinding requirements of the wide range of materials and valve diameters used in today's engines to assure superior finish.

IMPRESSIVE SPEED: The chuck is air-activated to open quickly to its full diameter at the touch of a button. Operators can work through a wide range of valve sizes without stopping to change collets. Stem end grinding, chamfering and rocker arm grinding features are all standard. Other machines may require you to grind the valve stem prior to refacing the valve. This is not required with the exclusive Kwik-Way Six-Ball Chuck. Dressing the wheel is extremely fast. The diamond dressing tool pivots out of the way when not in use.

SOLID WARRANTY: If you are looking for a valve refacer that could easily be your last, the Kwik-Way Valve Refacer is your solution. Kwik-Way is so confident this machine is built to last, it comes with a Three Year Warranty. The Kwik-Way SVS II Deluxe is designed to be your long-term machine for speed and accuracy.

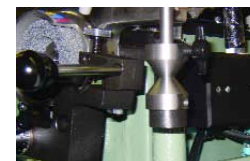

Smooth Finish • Butt End Grinding • Rocker Arm Grinding

Specifications

Minimum Chuck Capacity (Standard)	.157" (4.0mm)
Maximum Chuck Capacity (Standard)	.5625" (14.3mm)
	(up to 21mm with optional chuck)
Valve Head Diameter Capacity	.750" - 4" (19.05-101.6mm)
Minimum Stem Length	3.375" (85.73mm)
Valve Wheel Diameter	7" (178mm)
Surface Wheel Diameter	3" (76mm)
Spindle Drive Motor	1/2 HP
Chuck Drive Motor	Gear Drive 1/12 HP
Coolant Capacity	1 Gallon (3.8L)
Valve Wheel RPM/SFPM	3450 RPM/6322 SFPM
Stem Wheel RPM/SFPM	3450 RPM/2708 SFPM
Chuck Speed	Variable Speed: 100-300 RPM
Minimum Air Requirement	65 PSI
Overall Length	37" (940mm)
Overall Width	22" (599mm)
Overall Height	16" (406mm)
Height on (Optional) Stand	51" (1295mm)
Shipping Weight	292 lbs. (132.7 kg)

Standard Accessories

1/8" Hex Wrench	000-0600-54
5/32" Hex Wrench	000-0600-62
3/16" Hex Wrench	000-0600-70
1 Gallon (3.8L) Grinding Oil	000-2112-73
Chuck Assembly Tool	012-1060-09
Spanner Wrench	025-0150-02
Diamond Dressing Tool	024-0131-11
Spindle Lock Pin	013-0203-02

Optional Accessories

Valve Refacer Cabinet	012-0039-00
High Performance Chuck (.0002 or less)	
.157" - .5625" range (4.0-143mm)	012-1575-84
21mm Chuck	
7/16" 13/16" range (11.11 - 20.6mm)	012-1025-21

Order Information

SVS Series II Deluxe-I 15V/60Hz/IPh	012-0005-00
SVS Series II Deluxe-I 15V/60Hz/IPh with High Performance Chuck	012-0005-01
SVS Series II Deluxe-I 15V/60Hz/IPh with 7/16-13/16" (11.1-21mm) capacity chuck	012-0005-10
SVS Series II Deluxe-230V/50Hz/IPh	012-0005-20
SVS Series II Deluxe-230V/50Hz/IPh with High Performance Chuck	012-0005-03

Contact Your Local Distributor Today



Valve Refacers
& Cabinets



Boring Bars

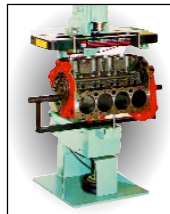

Boring Fixtures
& Stands



Seat Grinder Sets



Flywheel Grinders



Parts & Supplies

KWIK-WAY

www.kwik-way.com

800-553-5953

KW Products Inc.
500 57th Street
Marion, Iowa 52302 USA
1+ 319-377-9421
FAX: 319-377-9101