

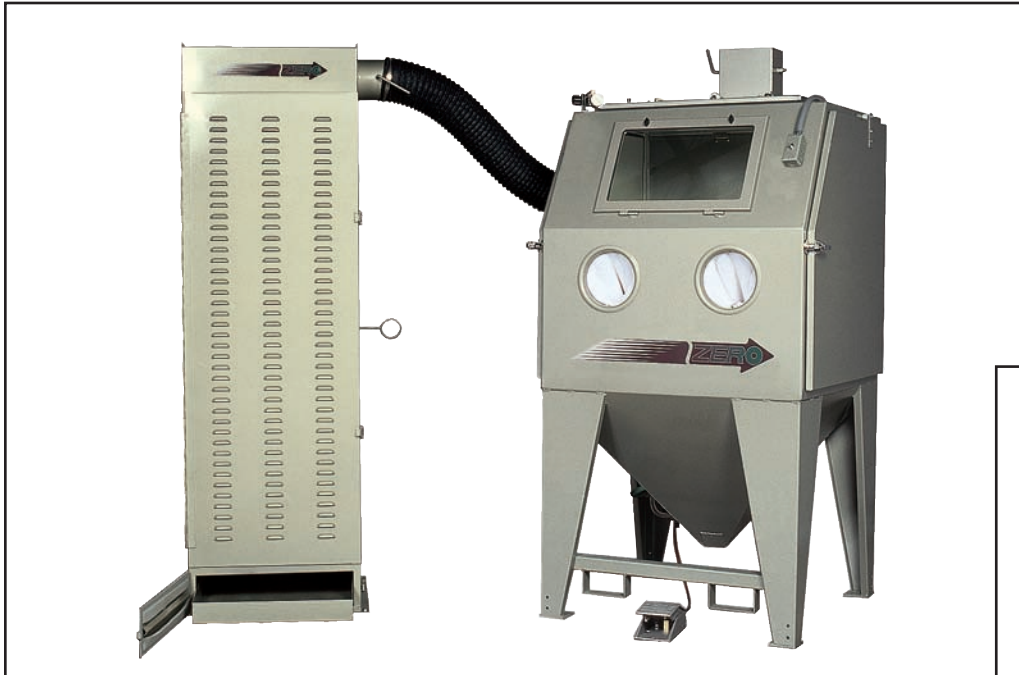

# BNP 65 Suction Blast Cabinet

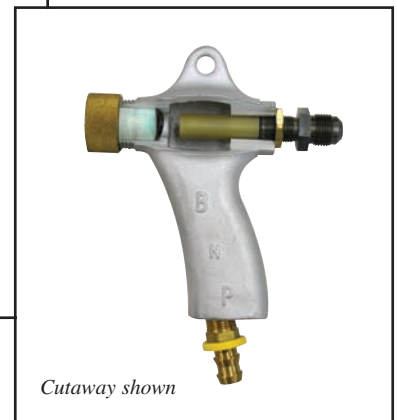

**Clean  
Peen  
Deburr  
Finish**



Cutaway shown

Model BNP 65-600 DF

**BNP blast cabinets deliver efficient, affordable media blasting to clean,peen, deburr, or finish parts.**

## Common Applications

- Remove rust, mill scale, heat scale, and carbon buildup from metals
- Strip paint, powder coating, plating, and anodizing from parts for rework
- Eliminate burrs, parting lines, flashings, and other defects from castings and injection-molded parts
- Extract residual sand from castings
- Beautify steel, stainless steel, aluminum, brass and other metals with a uniform matte finish
- Etch artwork and lettering into glass, stone, plastics, metal and other materials
- Clean release agents and material buildup from molds

## BNP 65 Cabinets Feature:

### Safety

- ✓ Full-length, neoprene-on-fabric gloves resist wear and protect operator.
- ✓ Ceiling-mounted, two-tube fluorescent light fixture with abrasive resistant Lexan® cover for extraordinary visibility.
- ✓ Safety interlocks interrupt blasting if either door is opened. (Conforms to US regulations.)
- ✓ Adjustable, heavy-duty chromed latches seal doors tight through years of service.

### Productivity

- ✓ Unique Air Logic system (pilot actuated) to maximize air flow to the blast gun.
- ✓ Double-wall, sound-insulated doors, with industrial-quality lift-off hinges.
- ✓ 14-gauge steel all-welded construction, with precisely formed bends, forms a rigid, long-lasting cabinet shell.

### Convenience

- ✓ Tilt-out window, for tool-free glass changes in minutes.
- ✓ Pressure regulator, gauge, and electric switch mounted within easy reach.
- ✓ Built-in blow-off gun helps keep dust inside the cabinet, not on your floor.

## BNP Blast Gun with Ceramic Nozzle

The BNP blast gun sets the industry standards for performance, versatility, and durability. The ergonomically proven grip reduces operator fatigue and increases productivity. The standard ceramic nozzle is perfect for bead blasting, while the optional tungsten or boron carbide nozzles stand up to hundreds of hours of blasting with today's aggressive abrasives.

## Popular Accessories

- Adjustable Gun Mount
- Adjustable Vortex Tube (for lightweight media)
- Alox Kit
- Air-powered Vertical Lift Door
- Curtains (black or high-visibility white)
- HEPA filter (RP model only)
- Manometer Kit
- Oscillator Assembly
- 20" and 24" Dia. Turntables
- Work Car & Track Assembly
- Two Gallon Tumble Basket
- Timed Door Release

# S P E C I F I C A T I O N S

## COMPLETE SYSTEM

Actual space required depends on equipment configurations, options and desired work flow. Allow additional work space for operator and maintenance access.

- A. 55" deep (includes rear-mounted reclaimer)
- B. 42" wide
- C. 79" high

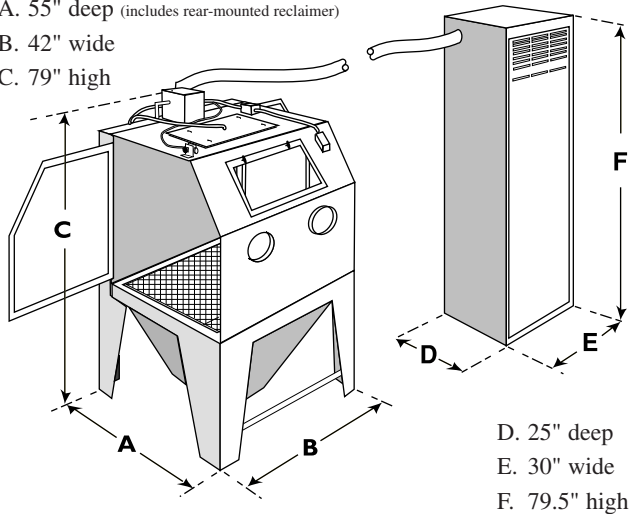

- D. 25" deep
- E. 30" wide
- F. 79.5" high

Model illustrated: BNP 65-600 DF  
600 CFM Reclaimer (rear mounted) and Dry Filter

## CABINET

### Working Chamber Size

36" wide (914 mm)  
35" deep (889 mm)  
37" high (940 mm)

### Door Opening

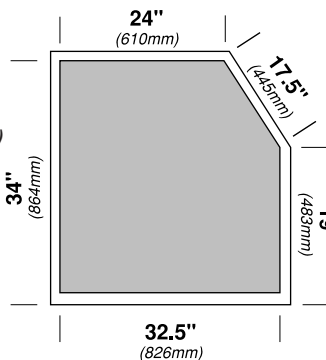

### Window Size (safety glass)

19.5" wide (495 mm)  
12.5" high (317 mm)

Door interlock system conforms to U.S. government regulations

## DUST COLLECTORS

Dry filters are suitable for most industrial applications where the dust collector can be shut off periodically to shake dust from the 100% cotton sateen filter tubes. Dry filters trap 98% of dust down to 1.0 micron.

Reverse pulse cartridge dust collectors (which trap 99.7% of dust down to 0.5 micron) allow non-stop, high-production blasting. The polyester-cellulose cartridges are automatically pulse cleaned for maximum filter efficiency. Worn cartridges can be replaced in minutes.

Dry Filters	Reverse Pulse Collector
5 sq ft filter area per tube 300 cfm DF has 15 tubes (75 sq ft) 600 cfm DF has 25 tubes (125 sq ft)	235 sq ft filter area per cartridge RPC-2 has two cartridges (470 sq ft)

Clemco is committed to continuous product improvement. Specifications are subject to change without notice.

Clemco Industries is an ISO 9001 certified company.

## MEDIA RECLAIMERS

### The Heart of ZERO's Blasting System

Our exclusive media reclaimers continuously extract dust and debris and return properly sized, usable media to the blast system. The standard reclaimer handles all non-metallic media. For metallic media, specify reduced ID conveying hose.

The suction blast metering valve is infinitely adjustable from fully-closed to wide open, and locks into any setting without tools.

The versatile design of our 600-cfm and larger reclaimers lets you quickly adapt the system to your changing needs—add media hoppers, a pressure blast system, or pull-through dust collection.

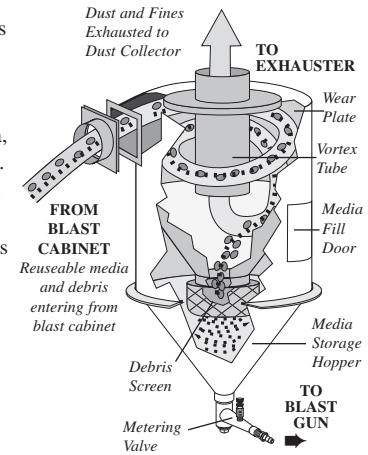

## BNP BLAST GUN

### AIR CONSUMPTION

BNP GUN	NOZZLE ORIFICE	AIR JET	CFM at 80 PSI	M <sup>3</sup> /Min at 5,5 BAR	MINIMUM RECLAIMER
No. 4	5/16"	1/8"	21	0,60	300 CFM (8,5 m <sup>3</sup> /m)
No. 5	5/16"	5/32"	32	0,90	300 CFM (8,5 m <sup>3</sup> /m)
No. 6	3/8"	3/16"	48	1,35	600 CFM (17 m <sup>3</sup> /m)
No. 7	7/16"	7/32"	62	1,76	600 CFM (17 m <sup>3</sup> /m)
No. 8	1/2"	1/4"	85	2,41	600 CFM (17 m <sup>3</sup> /m)

BNP 65 cabinets come standard with a No. 5 BNP gun. Other sizes and liner materials are available.

## ELECTRICAL

300 CFM (8,5 m<sup>3</sup>/m) 1/2HP, 115V, 1PH, 60HZ, (.37KW, 220V, 1PH, 50HZ); available with single phase motors only.

600 CFM (17 m<sup>3</sup>/m) 1HP, 115V, 1PH, 60HZ, (.75KW, 220V, 1PH, 50HZ); available with either single phase or three phase motors.

900 CFM (25 m<sup>3</sup>/m) 2HP, 220V, 3PH, 60HZ, (1.5KW, 220V, 3PH, 50HZ); available with three phase motors only.

For three phase motors, specify 230v or 460v.

Other motors and electrical configurations are available to make your system compatible with local power systems.

## ORDERING INFORMATION

Model Number	Reclaim CFM (m <sup>3</sup> /m)	Dust Collection	Single Phase	Three Phase	Ship Wt. lb (kg)
BNP-65-300 DB	300 (8,5)	Dust Bag	19941		555 (252)
BNP-65-300 DF	300 (8,5)	Dry Filter	19942		765 (347)
BNP-65-600 DB	600 (17)	Dust Bag	19945	19946	575 (261)
BNP-65-600 DF	600 (17)	Dry Filter	19947	19948	850 (385)
BNP-65-600 RPC	600 (17)	RPC-2	19950	19952	1,180 (535)
BNP-65M-900 DF	900 (25)	Dry Filter		22336	1,000 (455)

Distributed By: