

BNP Double 220 Pressure Blast Cabinet

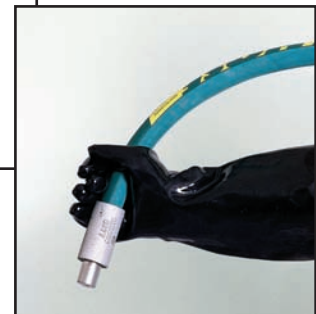

***Clean
Peen
Deburr
Finish***



Model BNP Double 220P-900 DF

For tough cleaning jobs, pressure blasting delivers higher abrasive velocity for greater impact intensity, compared to suction blasting, and can increase your production rate by as much as 300 percent.

Common Applications

- Remove rust, mill scale, heat scale, and carbon buildup from metals
- Strip paint, powder coating, plating, and anodizing from parts for rework
- Eliminate burrs, reduce parting lines, remove flashings and other defects from castings and injection-molded parts
- Extract residual sand from castings
- Beautify steel, stainless steel, aluminum, brass and other metals with a uniform matte finish
- Etch artwork and lettering into glass, stone, plastics, metal and other materials
- Clean release agents and material buildup from molds

BNP Double 220 Pressure Cabinets Feature:

Safety

- ✓ Full-length, neoprene-on-fabric gloves resist wear and protect operator.
- ✓ Safety interlocks interrupt blasting if either door is opened.

Productivity

- ✓ Two stations provide easy access to blast from either station to accommodate long or complex parts. One nozzle and foot pedal are standard.
- ✓ High efficiency, 2.0 cubic foot capacity, ASME-coded pressure vessel, fitted with 1" ID piping, industrial-quality blast hose and couplings, and cabinet integrated controls.
- ✓ Unique Air Logic system (pilot actuated) to maximize air flow to the nozzle.
- ✓ Ceiling-mounted, two-tube fluorescent light fixture with abrasive resistant Lexan® cover for extraordinary visibility.
- ✓ 14-gauge steel all-welded construction forms a rigid, long-lasting cabinet shell.

Convenience

- ✓ Tilt-out window, for tool-free glass changes in minutes.
- ✓ Double-wall, sound-insulated doors on both ends feature industrial-quality lift-off hinges.
- ✓ Pressure regulator, gauge, air and electric switch mounted within easy reach.
- ✓ Built-in blow-off gun helps keep dust inside the cabinet, not on your floor.

Tungsten Carbide Blast Nozzle

The standard No. 3 (3/16-inch) tungsten carbide nozzle is perfect for most blasting, while an optional boron carbide nozzle stands up to hundreds of hours of blasting with aluminum oxide or other aggressive media. The cabinet's blast and recovery systems can support up to a No. 4 (1/4-inch) nozzle.

Popular Accessories

- Dual nozzle upgrade pkg.
- Adjustable Gun Mount
- Adjustable Vortex Tube (for lightweight media) (stand on RP models)
- Air-powered Vertical Lift Door
- Aggressive Media Kit
- Curtains (black or high-visibility white)
- HEPA Filter (RP model only)
- Manometer Kit
- Time-delay door Interlocks
- 20" and 30" Dia. Turntables
- Work Car & Track Assembly
- A-300 Automation Kit

S P E C I F I C A T I O N S

COMPLETE SYSTEM

Actual space required depends on equipment configurations, options and desired work flow. Allow additional work space for operator and maintenance access.

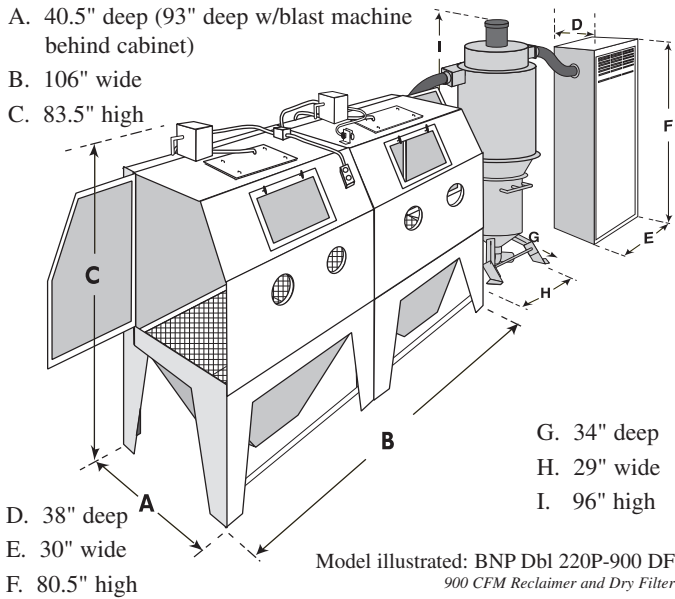

CABINET

Working Chamber Size

103" wide (2550 mm)
 39" deep (991 mm)
 43" high (1092 mm)

Window Size (safety glass)

19.5" wide (495 mm)
 12.5" high (318 mm)

Door Opening

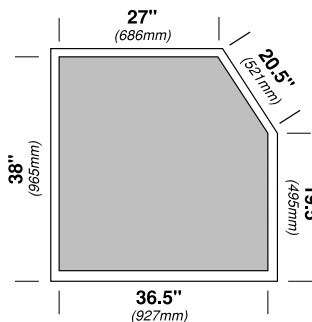

DUST COLLECTORS

Dry filters are suitable for most industrial applications where the dust collector can be shut off periodically to shake dust from the 100% cotton sateen filter tubes.

Dry filters trap 98% of dust down to 1.0 micron.

Reverse pulse cartridge dust collectors (which trap 99.7% of dust down to 0.5 micron) allow non-stop, high-production blasting. The polyester-cellulose cartridges are automatically pulse cleaned for maximum filter efficiency. RPH collectors feature built-in hoppers to minimize dust handling.

Dry Filters	Reverse Pulse Collector
5 sq ft filter area per tube 900 cfm DF has 40 tubes (200 sq ft)	235 sq ft filter area per cartridge RPC-2 has two cartridges (470 sq ft)

Clemco is committed to continuous product improvement. Specifications are subject to change without notice.

Clemco Industries is an ISO 9001-2000 certified.

BLAST/ RECLAIM SYSTEM

The Heart of ZERO's Blasting System

Our exclusive media reclaimers continuously extract dust and debris and return properly sized, usable media to the blast system. The standard reclaimer handles all non-metallic media. For metallic media, specify reduced ID conveying hose.

Our versatile design lets you quickly adapt the system to your changing needs - media-add hoppers, rubber liners, or pull-through dust-collection.

The reclaimer, mounted atop the blast machine, automatically refills the blast system with clean, recycled media.

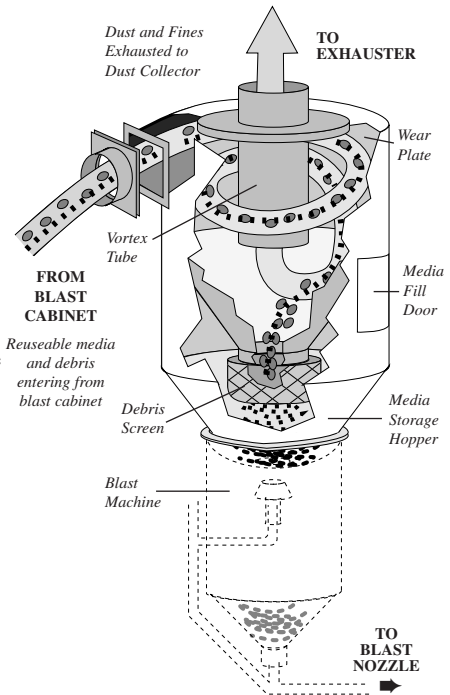

NOZZLES

AIR REQUIREMENTS

NOZZLE	NOZZLE ORIFICE	CFM at 80 PSI	M ³ /Min at 5,5 BAR	CFM at 100 PSI	M ³ /Min at 7 BAR
No. 3	3/16"	38	1,08	45	1,3
No. 4	1/4"	68	1,93	81	2,3
No. 5	5/16"	113	3,20	137	4,0*

BNP Double-220 pressure cabinets are furnished with a No. 3 tungsten carbide nozzle.
 *Use of a 5/16" nozzle requires other equipment considerations. Consult distributor.

ELECTRICAL

900 CFM (25 m³/m) 2HP, 230V, 3PH, 60HZ (1.5KW, 220V, 3PH, 50HZ); available with three phase motors only.

Specify 230v or 460v on order.

Other motors and electrical configurations are available upon request.

ORDERING INFORMATION

Model Number	Dust Collection	Reclaim CFM (m ³ /m)	Stock Number	Ship Wt. lb (kg)
BNP-Dbl 220P-900 DF	900 (25)	Dry Filter	21158	2,035 (925)
BNP-Dbl 220P-900 RPH	900 (25)	RPH	21159	2,890 (1,314)

Distributed By: