

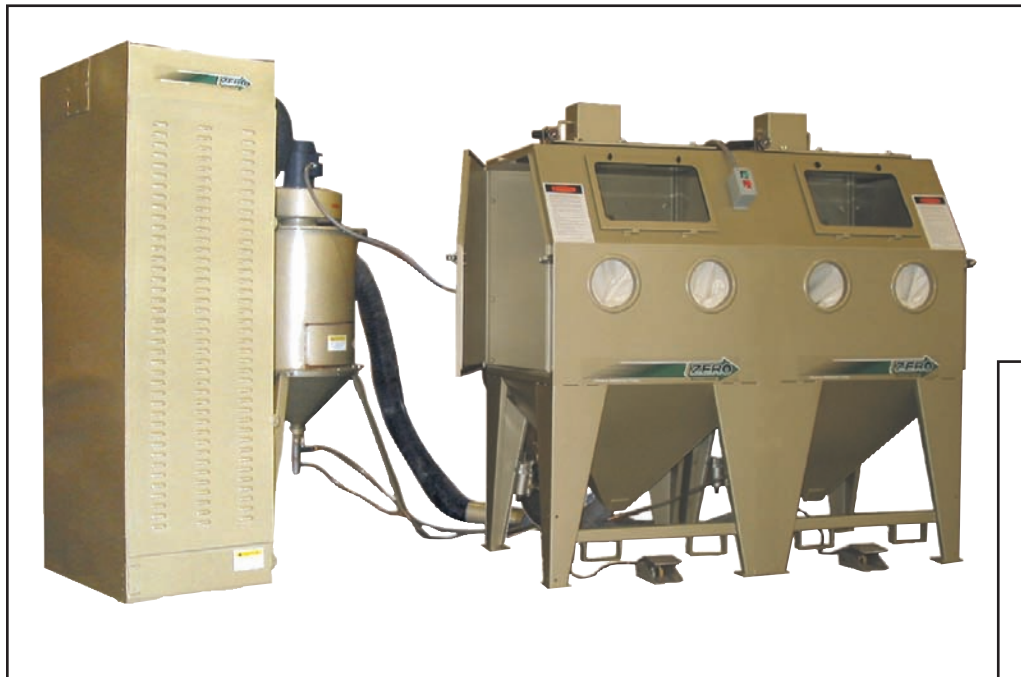

# BNP Double 65 Suction Blast Cabinet

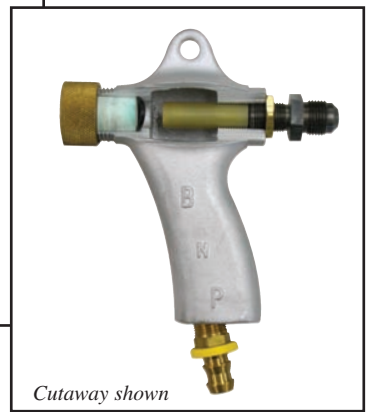

**Clean  
Peen  
Deburr  
Finish**



*Cutaway shown*

*Model BNP Double 65-900 DF*

**BNP blast cabinets deliver efficient, affordable media blasting to clean, peen, deburr, or finish parts.**

## Common Applications

- Remove rust, mill scale, heat scale, and carbon buildup from metals
- Strip paint, powder coating, plating, and anodizing from parts for rework
- Eliminate burrs, reduce flashings, and other defects from castings and injection-molded parts
- Extract residual sand from castings
- Beautify steel, stainless steel, aluminum, brass and other metals with a uniform matte finish
- Etch artwork and lettering into glass, stone, plastics, metal and other materials
- Clean release agents and material buildup from molds

## BNP Double 65 Cabinets Feature:

### Safety

- ✓ Full-length, neoprene-on-fabric gloves resist wear and protect operator.
- ✓ Safety interlocks interrupt blasting if either door is opened.

### Productivity

- ✓ Unique Air Logic system (pilot actuated) to maximize air flow to the blast gun.
- ✓ Two stations provide easy access to blast from either side or both sides simultaneously.
- ✓ Ceiling-mounted, two-tube fluorescent light fixtures with abrasive resistant Lexan® cover for extraordinary visibility.
- ✓ 14-gauge steel all-welded construction, with precisely formed bends, forms a rigid, long-lasting cabinet shell.
- ✓ Double suction-blast cabinet features two blast guns as standard.

### Convenience

- ✓ Tilt-out window, for tool-free glass changes in minutes.
- ✓ Double-wall, sound-insulated doors, with industrial-quality lift-off hinges.
- ✓ Pressure regulator, gauge, and electric switch mounted within easy reach.
- ✓ Built-in blow-off gun helps keep dust inside the cabinet, not on your floor.

## BNP Blast Gun with Ceramic Nozzle

The BNP blast gun sets the industry standards for performance, versatility, and durability. The ergonomically proven grip reduces operator fatigue and increases productivity. The standard ceramic nozzle is perfect for bead blasting, while the optional tungsten or boron carbide nozzles stand up to hundreds of hours of blasting with today's aggressive abrasives.

## Popular Accessories

- Adjustable Gun Mount
- Adjustable Vortex Tube (for lightweight media)
- Alox Kit
- Air-powered Vertical Lift Door
- Curtains (black or high-visibility white)
- HEPA filter (RP model only)
- Manometer Kit
- Oscillator Assembly
- 20" and 30" Dia. Turntables
- Work Car & Track Assembly
- Two Gallon Tumble Basket
- Timed Door Interlocks

# S P E C I F I C A T I O N S

## COMPLETE SYSTEM

Actual space required depends on equipment configurations, options and desired work flow. Allow additional work space for operator and maintenance access.

- A. 36.5" deep (84" with free standing reclaimer)
- B. 76" wide
- C. 81" high

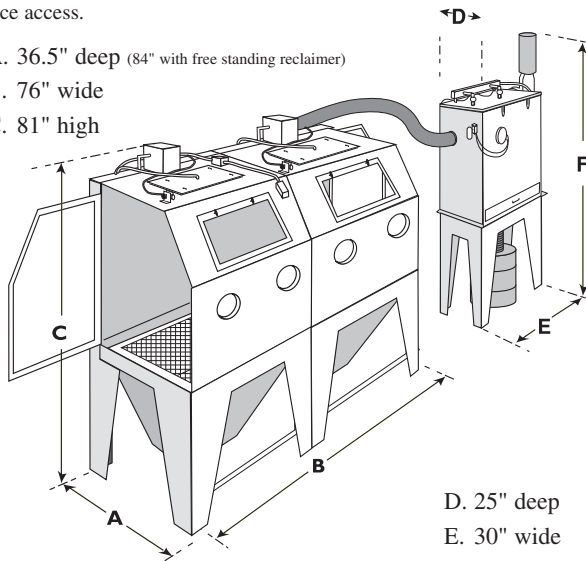

- D. 25" deep
- E. 30" wide
- F. 79.5" high

Model illustrated: BNP Double 65-900 RPH  
900 CFM Reclaimer (free standing) and Reverse Pulse Collector with Hopper

## CABINET

### Working Chamber Size Door Opening

73" wide (1854 mm)  
35" deep (889 mm)  
37" high (940 mm)

### Window Size (safety glass)

19.5" wide (495 mm)  
12.5" high (318 mm)

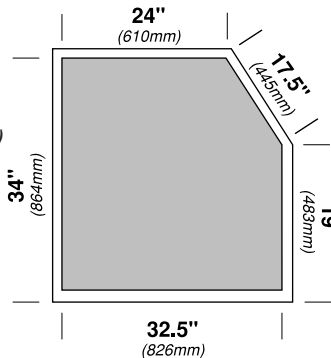

## DUST COLLECTORS

Dry filters are suitable for most industrial applications where the dust collector can be shut off periodically to shake dust from the 100% cotton sateen filter tubes.

Dry filters trap 98% of dust down to 1.0 micron.

Reverse pulse cartridge dust collectors (which trap 99.7% of dust down to 0.5 micron) allow non-stop, high-production blasting. The polyester-cellulose cartridges are automatically pulse cleaned for maximum filter efficiency. Worn cartridges can be replaced in minutes.

Dry Filters	Reverse Pulse Collector
5 sq ft filter area per tube 900 cfm DF has 40 tubes (200 sq ft)	235 sq ft filter area per cartridge RPC-2 has two cartridges (470 sq ft) RPH-2 has two cartridges (470 sq ft)

Clemco is committed to continuous product improvement. Specifications are subject to change without notice.

Clemco Industries is an ISO 9001 certified company.

© 2007 Clemco Industries Corp. • Washington, MO 63090 • 636 239-4300 • FAX 800 726-7559

Stock No.: 24892

info@clemcoindustries.com • www.clemcoindustries.com

Job No.: 2189-0107 Rev. A, 05/07

## MEDIA RECLAIMERS

### The Heart of ZERO's Blasting System

Our exclusive media reclaimers continuously extract dust and debris and return properly sized, usable media to the blast system. The standard reclaimer handles all non-metallic media. For metallic media, specify reduced ID conveying hose.

The suction blast metering valve is infinitely adjustable and locks into any setting without tools.

The versatile design of our 600-cfm and larger reclaimers lets you quickly adapt the system to your changing needs—add media hoppers, a pressure blast system, or pull-through dust collection.

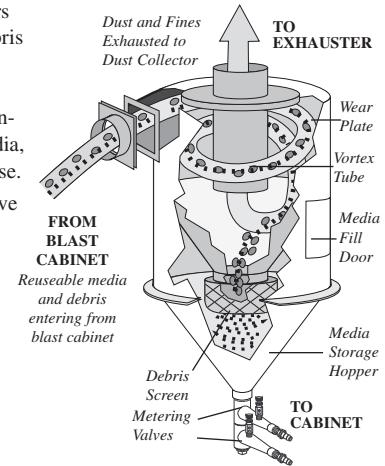

## BNP BLAST GUN

### AIR CONSUMPTION

BNP GUN	NOZZLE ORIFICE	AIR JET	CFM at 80 PSI	M <sup>3</sup> /Min at 5,5 BAR	MINIMUM RECLAIMER
No. 4	5/16"	1/8"	21	0,60	900 CFM (25 m <sup>3</sup> /m)
No. 5	5/16"	5/32"	32	0,90	900 CFM (25 m <sup>3</sup> /m)
No. 6	3/8"	3/16"	48	1,35	900 CFM (25 m <sup>3</sup> /m)

BNP Double 65 cabinets come standard with two No. 5 BNP guns.  
Other sizes and liner materials are available.

## ELECTRICAL

900 CFM (25 m<sup>3</sup>/m) 2HP, 230V, 3PH, 60HZ, (1.5KW, 220V, 3PH, 50HZ); available with three phase motors only.

Specify 230v or 460v.

Other motors and electrical configurations are available upon request..

## ORDERING INFORMATION

Model Number	Reclaim CFM (m <sup>3</sup> /m)	Dust Collection	Stock Number	Ship Wt. lb (kg)
BNP Dbl 65S-900 DF	900 (25)	Dry Filter	12571	1,180 (536)
BNP Dbl 65S-900 RPC	900 (25)	RPC-2	14379	1,601 (728)
BNP Dbl 65S-900 RPH	900 (25)	RPH-2	14380	2,162 (983)

Larger nozzles and reclaimers are available upon request.

Distributed By: